

INSTALLATION FOR RAPID RIDGE

Step 1:

Snap chalk line and cut a slot 3" wide (1 1/2" on each side of ridge beam). Allow for a closed area of sheathing 18" at both ends of ridge.

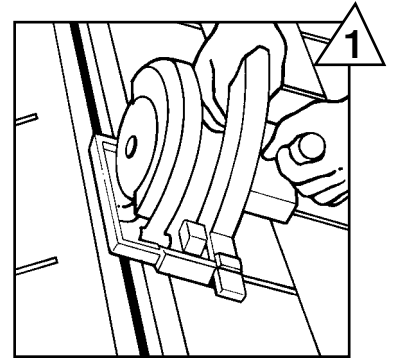

Step 2:

No end cap is necessary if ridge cap shingles are lapped over end of product and down onto ridge. In this case, run vent to 12" from gable ends. Cap shingles can be laid down over end of vent onto ridge out to gable ends. Optionally, Rapid Ridge can be installed right to gable ends using an integral end cap. To create end cap, loosen about 6" of matrix from fabric and cut out with snips. Fold bottom fabric in toward center of product so that it covers the end of vent. Start and end vent installation 1" from gable ends.

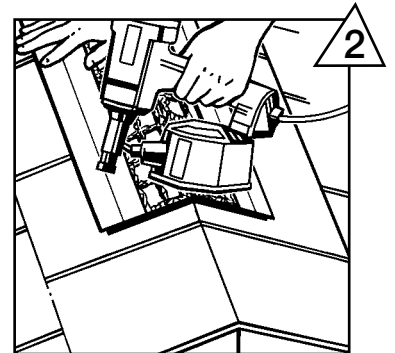

Step 3:

Center vent over slot at one end with nail lines "up" and fasten with two nails (note: minimum nail length is 1 3/4"). Recommended nail gun compressor pressure is between 90 and 100 psi. Roll out along entire ridge, pull out slack, and fasten with two nails at opposite end (creating end cap at other end if using that method). Center ridge cap shingles over vent and install with 1 3/4" collated nails provided. Use nail line as placement guide. If using fabric end cap, hang shingles 1" over vent at gable ends. Nails must penetrate into sheathing 3/4" or completely through the sheathing.

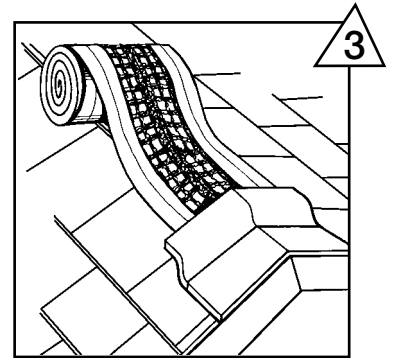

Step 4:

To splice, remove about 3" of nylon matrix from fabric and lay end of new roll inside remaining fabric to create fabric overlap.

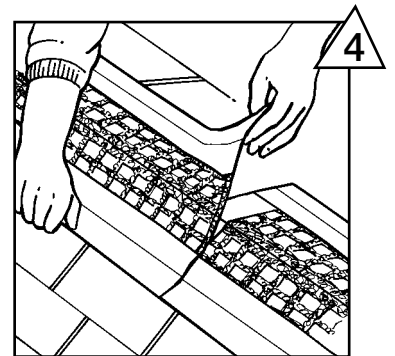

**BENJAMIN
OBDYKE**

For additional information call:

800-346-7655

INSTALLATION FOR RAPID RIDGE METRIC

Step 1:

Snap chalk line and cut slot 3" (7.6 cm) wide (1 1/2" {3.8 cm} on each side of ridge beam). Allow for a closed area of sheathing 18" (46 cm) at both ends of the ridge.

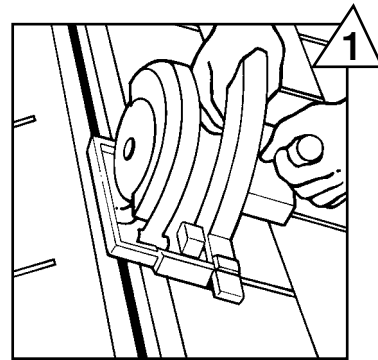

Step 2:

No end cap is necessary if ridge cap shingles are lapped over end of product and down onto ridge. In this case, run vent to 12" (30 cm) from the gable ends. Cap shingles can be laid down over end of vent onto ridge and out to gable ends. Optionally, Rapid Ridge can be installed right to gable ends using an integral end cap. To create end cap, loosen about 6" (15.24 cm) of matrix from fabric and cut out with snips. Fold bottom fabric in toward center of product so that it covers the end of vent. Start and end vent installation 1" (2.5 cm) from gable ends.

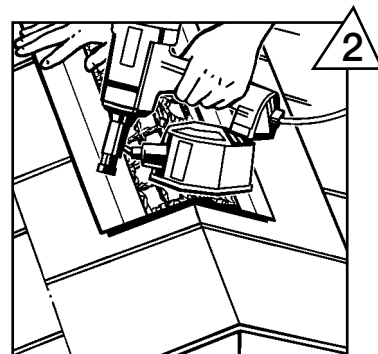

Step 3:

Center vent over slot at one end with nail lines "up" and fasten with two nails (note: minimum nail length is 1 3/4" {4.4 cm}). Recommended nail gun compressor pressure is between 90 and 100 psi. Roll out along entire ridge, pull out slack, and fasten with two nails at opposite end (creating end cap at other end if using that method). Center ridge cap shingles over vent and install with 1 3/4" (4.4 cm) collated nails provided. Use nail line as placement guide. If using fabric end cap, hang shingles 1" (2.5 cm) over vent at gable ends. Nails must penetrate into sheathing 3/4" (1.9 cm) or completely through the sheathing.

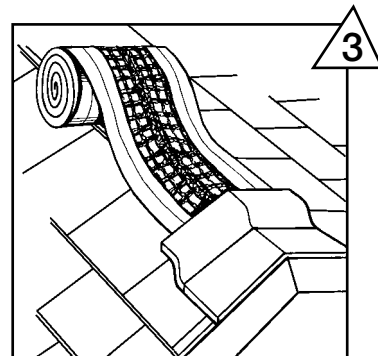

Step 4:

To splice, remove about 3" (7.62 cm) of nylon matrix from fabric and lay end of new roll inside remaining fabric to create fabric overlap.

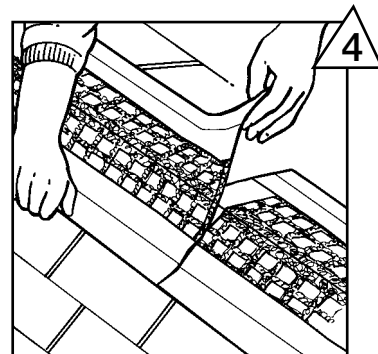

**BENJAMIN
OBDYKE**

For additional information call:

800-346-7655

INSTALLATION FOR RAPID RIDGE 7

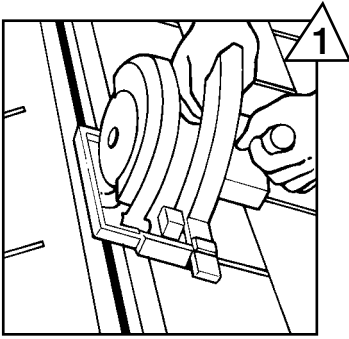

Step 1:
Snap chalk line and cut slot 2" wide (1" on each side). Allow for a closed area of sheathing 12" at both ends of the ridge.

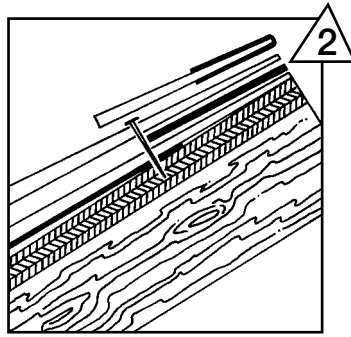

Step 2:
Fold 30 lb. felt back over last course of shingles/ shakes/ tiles exposing 2" slot. (When cutting last course of shingles/ shakes/ tiles, use caution to avoid cutting through felt.)

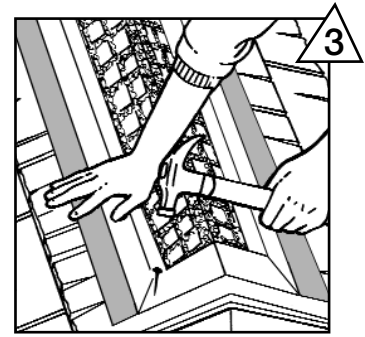

Step 3:
To create end cap, loosen about 6" of matrix from fabric and cut out with snips. Fold bottom fabric in toward center of product so that it covers the end of vent. Center vent over slot at one end with nail lines "up" and fasten with two nails. Roll out along entire ridge, pull out slack, and fasten with two nails at opposite end (creating end cap at other end). Start and end vent installation 1" from gable ends.

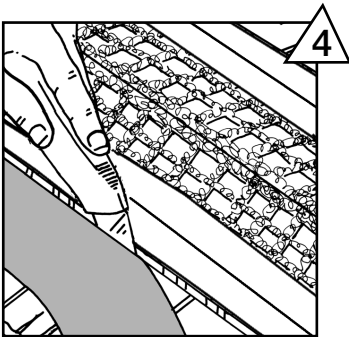

Step 4:
Cut exposed excess felt away on shingles/shakes/ tiles. In areas of severe weather or rough hand split shakes, lay a bead of caulk between felt and Rapid Ridge 1/4" in from edge for entire length of Rapid Ridge.

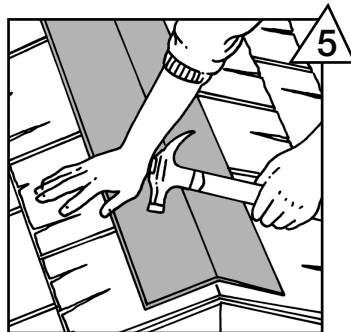

Step 5:
Install 30 lb felt 7" wide on top of entire length of Rapid Ridge (optional on asphalt shingles).

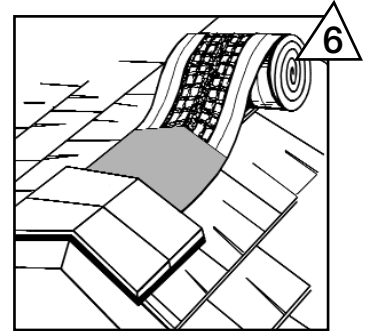

Step 6:
Center ridge cap shingles/ shakes/ tiles over vent and install with appropriate nails. Use nail length that penetrates into sheathing 3/4" or completely through the sheathing. Nail approximately 1 3/4" in from ridge cap edge on nailing rib indicated by nailing line. Hang shingles 1" over vent at gable ends.

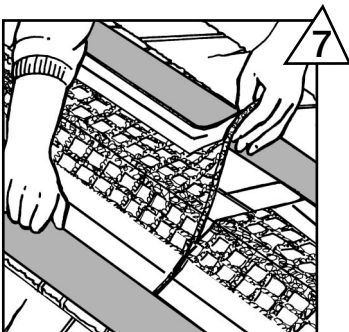

Step 7:
To splice, remove about 3" of nylon matrix from fabric and lay end of new roll inside remaining fabric to create fabric overlap.

**BENJAMIN
OBDYKE**

For additional information call:
800-346-7655

APPLICATION & ARCHITECTURAL DRAWINGS

	PAGE
ASPHALT FIBERGLASS SHINGLES	2
INSTALLATION WITH RIDGE BEAM	3
HIP ROOF	4
STEEP PITCH	5
SHED ROOF	6
STANDING SEAM	7
OFF PEAK	8
CATHEDRAL CEILINGS	9
NO-SLOT VENT	10
RAPID RIDGE 7 INSTALLATION	11



RAPID RIDGE[®]
NAIL GUN-ABLE RIDGE VENT

ASPHALT FIBERGLASS SHINGLES

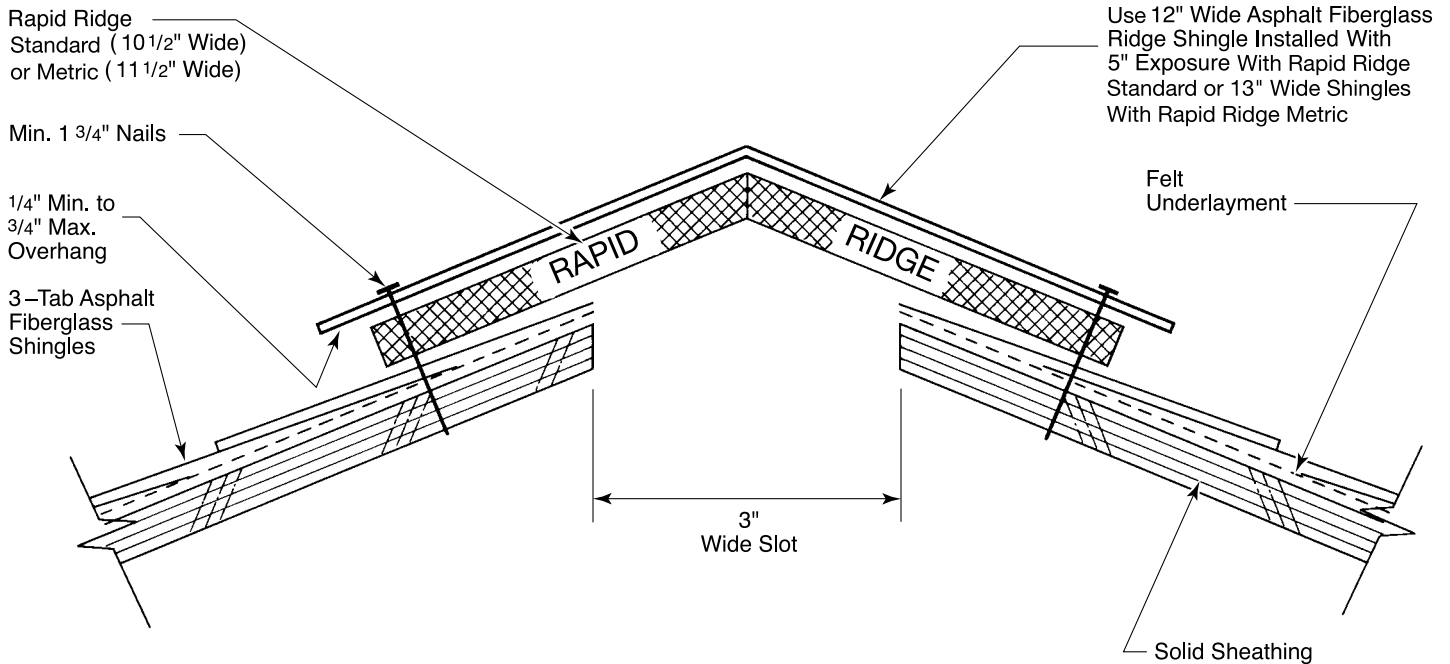

Note: Install with continuous soffit ventilation at each eave equivalent to 7 sq. in. per linear foot.

Installs on pitches 3/12 to 18/12. For pitches greater than 12/12, refer to page 5.

Use Rapid Ridge Standard (10 1/2") for 12" three-tab shingles. Use Rapid Ridge Metric (11 1/2") for metric shingles approximately 13" wide.

If installing on dimensional or architectural shingles on new construction, leave felt underlayment about 6" long at roof ridge and fold back under the vent so that vent is essentially installed on top of felt over the shingles. If re-roofing, caulk between low areas of shingle and baffle of vent after installation.

1. Snap chalk line and cut a slot 3" wide (1 1/2" on each side of ridge beam). Allow for a closed area of sheathing 18" at both ends of ridge.
2. No end cap is necessary if ridge cap shingles are lapped over end of product and down onto ridge. In this case, run vent to 12" from gable ends. Cap shingles can be laid down over end of vent onto

ridge out to gable ends. Optionally, Rapid Ridge can be installed right to gable ends using an integral end cap. To create end cap, loosen about 6" of matrix from fabric and cut out with snips. Fold bottom fabric in toward center of product so that it covers the end of vent. Start and end vent installation 1" from gable ends.

3. Center vent over slot at one end with nail lines "up" and fasten with two nails (note: minimum nail length is 1 3/4"). Recommended nail gun compressor pressure is between 90 and 100 psi. Roll out along entire ridge, pull out slack, and fasten with two nails at opposite end (creating end cap at other end if using that method). Center ridge cap shingles over vent and install with 1 3/4" collated nails provided. Use nail line as placement guide. If using fabric end cap, hang shingles 1" over vent at gable ends. Nails must penetrate into sheathing 3/4" or completely through the sheathing.
4. To splice, remove about 3" of nylon matrix from fabric and lay end of new roll inside remaining fabric to create fabric overlap.

INSTALLATION WITH RIDGE BEAM

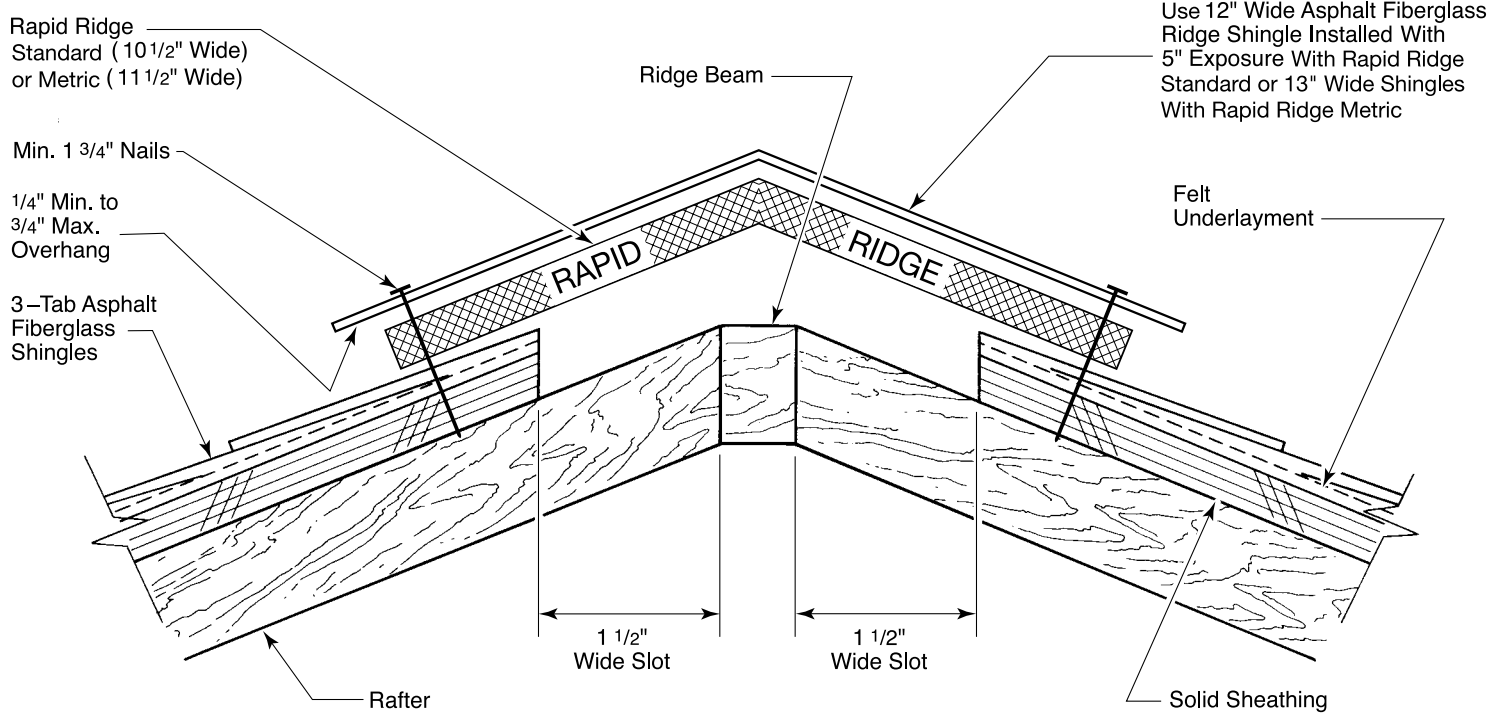

Note: If ridge beam is wider than 2", refer to Rapid Ridge Off Peak Application.

Install with continuous soffit ventilation at each eave equivalent to 7 sq. in. per linear foot.

Installs on pitches 3/12 to 18/12. For pitches greater than 12/12, refer to page 5.

Use Rapid Ridge Standard (10 1/2") for 12" three-tab shingles. Use Rapid Ridge Metric (11 1/2") for metric shingles approximately 13" wide.

If installing on dimensional or architectural shingles on new construction, leave felt underlayment about 6" long at roof ridge and fold back under the vent so that vent is essentially installed on top of felt over the shingles. If re-roofing, caulk between low areas of shingle and baffle of vent after installation.

1. Snap chalk line and cut slot 1 1/2" on each side of ridge beam. Allow for a closed area of sheathing 18" at both ends of ridge.
2. No end cap is necessary if ridge cap shingles are lapped over end of product and down onto ridge. In this case, run vent to 12" from gable ends. Cap shingles can be laid down over end of vent onto

ridge out to gable ends. Cap shingles can be laid down over end of vent onto ridge out to gable ends. Optionally, Rapid Ridge can be installed right to gable ends using an integral end cap. To create end cap, loosen about 6" of matrix from fabric and cut out with snips. Fold bottom fabric in toward center of product so that it covers the end of vent. Start and end vent installation 1" from gable ends.

3. Center vent over slot at one end with nail lines "up" and fasten with two nails (note: minimum nail length is 1 3/4"). Recommended nail gun compressor pressure is between 90 and 100 psi. Roll out along entire ridge, pull out slack, and fasten with two nails at opposite end (creating end cap at other end if using that method). Center ridge cap shingles over vent and install with 1 3/4" collated nails provided. Use nail line as placement guide. If using fabric end cap, hang shingles 1" over vent at gable ends. Nails must penetrate into sheathing 3/4" or completely through the sheathing.
4. To splice, remove about 3" of nylon matrix from fabric and lay end of new roll inside remaining fabric to create fabric overlap.

HIP ROOF

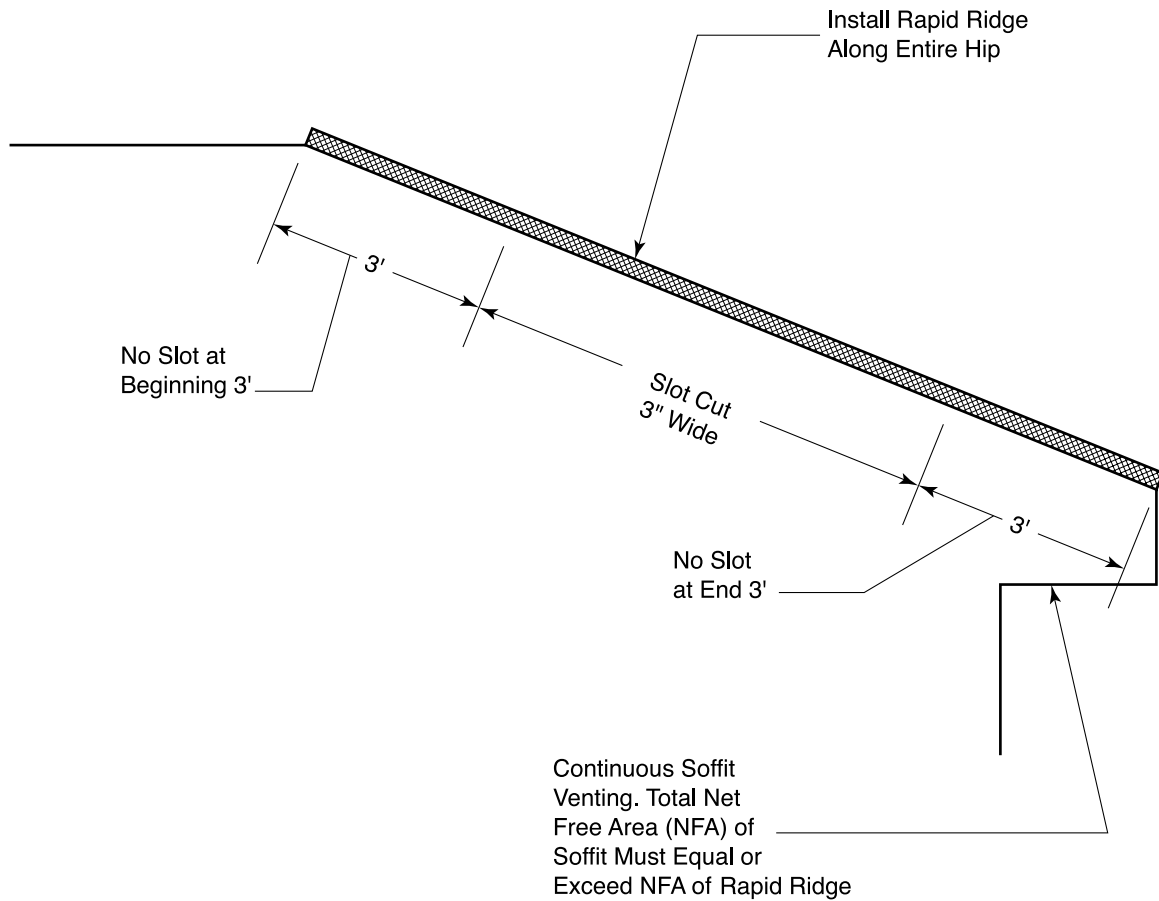

Note: Hip application not to exceed 12/12 pitch.

Cut slot in roofing along hip 3" wide beginning 3' from peak and running to 3' of end of hip. Start Rapid Ridge a minimum of 1" from each end of the hip using the end cap installation (pg 2). Install ridge/hip cap shingles over vent and install with 1 3/4" collated nails provided. Use nail line as placement guide. Nails must penetrate into the sheathing 3/4" or completely through the sheathing. Ridge cap shingles must overhang Rapid Ridge by 1" at each hip end.

Run bead of sealant along bottom edge of Rapid Ridge where it meets shingles on roof deck. Hip application is for Rapid Ridge Standard (10 1/2") or Rapid Ridge Metric (11 1/2").

STEEP PITCH

As a roof's pitch becomes steeper, the effective opening of the slot becomes smaller. To provide effective ventilation, the slot cut must be wider than normal.

The following chart gives the necessary measurements of the slot width for roofs with higher than 12/12 pitches.

PITCH	EACH SIDE	TOTAL SLOT
13/12	2 3/16"	4 3/8"
14/12	2 1/4"	4 1/2"
15/12	2 3/8"	4 3/4"
16/12	2 1/2"	5"
17/12	2 5/8"	5 1/4"
18/12	2 11/16"	5 3/8"

Under no circumstances should Rapid Ridge be installed on pitches over 18/12. This steep pitch application is for ridge installations using Rapid Ridge Standard (10 1/2") or Rapid Ridge Metric (11 1/2").

The presence of a ridge beam may slightly reduce ventilation effectiveness.



SHED ROOF

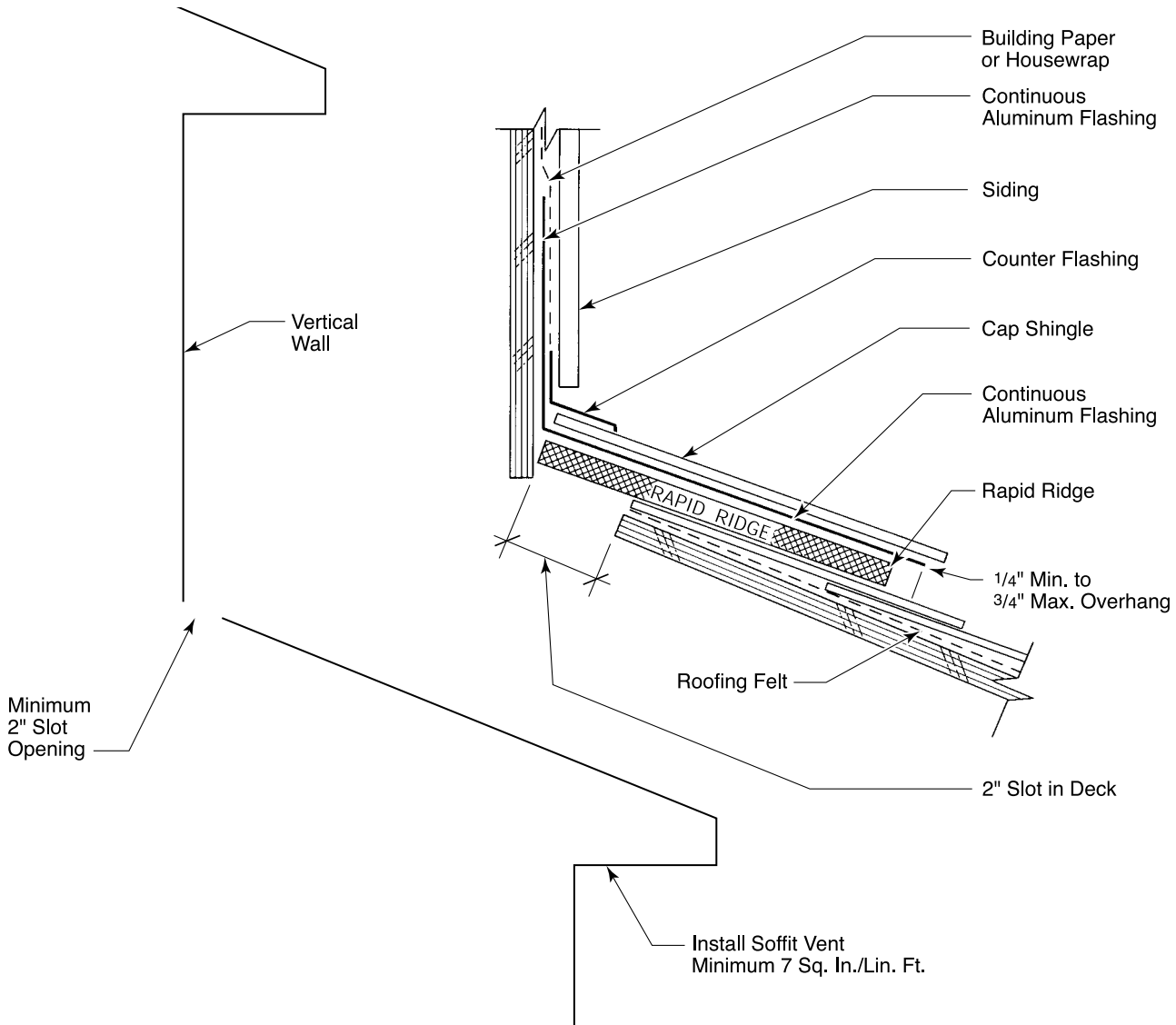

Note: Rapid Ridge will only vent 6.25 sq. in. per linear foot in this application. The Venturi effect will be limited.

Cut a slot 2" wide in roof deck where roof meets vertical wall. Allow for a closed area of sheathing 6" at both ends.

Start Rapid Ridge a minimum of 1" from each end of roof using the end cap installation (pg 2). Center ridge cap shingles over vent and install with minimum

1 3/4" nails. Use nail line as placement guide. Nails must penetrate into the sheathing 3/4" or completely through the sheathing. Ridge cap shingles must overhang Rapid Ridge by 1" minimum at each gable end.

For added weather protection, install counter flashing behind siding and over top of cap shingle.

STANDING SEAM

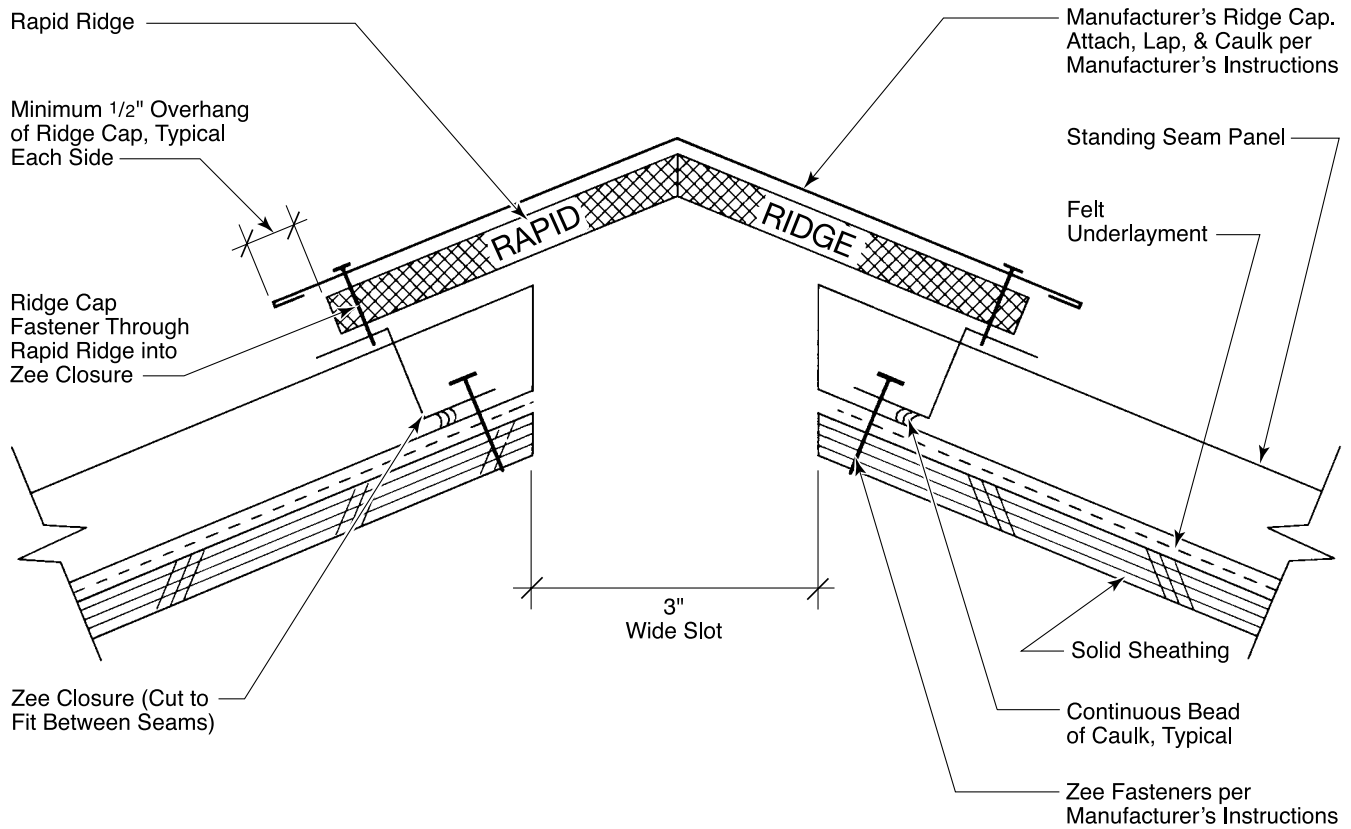

Note: Install with continuous soffit ventilation at each eave equivalent to 7 sq. in. per linear foot.

Rapid Ridge available in Standard (10 1/2"), 7 (7") and Metric (11 1/2") widths. Choose width that will allow ridge cap to overhang Rapid Ridge by 1/2" minimum on each side. If using Rapid Ridge 7, slot should only be 2" wide.



OFF PEAK

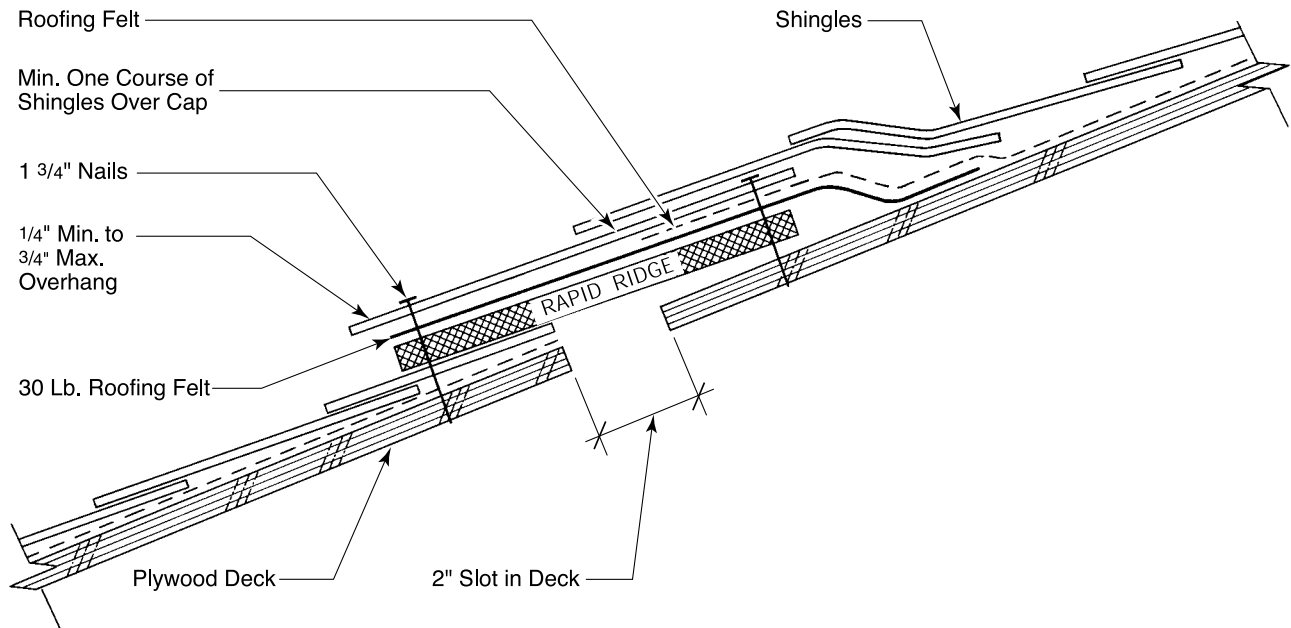

Note: Rapid Ridge will only vent 6.25 sq. in. per linear foot in this application and must be installed with a soffit vent with a minimum of 7 sq. in. per linear foot net free area. It is recommended that Rapid Ridge and soffit vent be installed on both sides of the peak.

1. Cut 2" wide slot in deck no more than 4' from ridge and no closer than 4' from eave. Allow for closed area of sheathing with no slot approximately 6" at both ends.
2. Install felt per manufacturer's instructions onto deck leaving slot exposed. Do not nail or staple through felt within 8" of slot opening on high side of slot.
3. Shingle per manufacturer's instructions up to slot.
4. Center Rapid Ridge over slot, tack down at end and roll out. Start Rapid Ridge a minimum of 1" from each end of roof using the end cap installation (pg 2).
5. Install minimum 14" wide 30 lb. felt on top of Rapid Ridge and lap felt from deck on top of this course of felt.
6. Install one-tab ridge cap shingles over felt and Rapid Ridge with 1 3/4" collated nails provided. Use nail line as placement guide. Nails must penetrate into the sheathing 3/4" or completely through the sheathing. Ridge cap shingles must overhang Rapid Ridge by 1" at each gable end. Ridge cap shingles should overhang Rapid Ridge by 1/4" minimum to 3/4" maximum on each side. Three-tab shingles can be used as this course provided minimum 1 3/4" nails are placed on each tab 1" from lower edge of Rapid Ridge and nail heads are sealed in caulk.
7. Install minimum one course of shingles lapped on top of cap. Install rest of shingles per manufacturer's instructions.

CATHEDRAL CEILINGS

Cathedral or vaulted ceilings present some unique ventilating situations that need to be addressed up front to avoid condensation problems down the road. A cathedral ceiling is typically constructed utilizing 2 x 8 rafters on 16" or 24" centers; plywood roof decking on top of the rafters; and drywall, which becomes the ceiling of the room below, on the bottom of the rafters. Since this rafter space becomes the only separation between living space and outside temperatures, many builders want to install as much insulation as possible in this space. This causes a problem by restricting the air flow capability from soffit (intake) to ridge (exhaust) within these rafter spaces. This usually shows up in the form of condensation. The following are tips to follow when designing or installing Rapid Ridge for use in cathedral/vaulted ceilings:

1. Be sure to properly “balance” the Rapid Ridge total net free area with soffit vent total net free area. Strip soffit vent with a net free area of at least 9 sq. in. per linear foot is necessary.
2. Install Rapid Ridge and soffit venting continuously along the ridge and eave overhang, respectively. Each rafter space must have air flow.
3. Install “vent chutes” between the rafters from the soffit to the ridge. This assures at least 1 1/2" of unobstructed air space between the bottom of the deck and top of the insulation.
4. Install a vapor barrier on the “warm” side of the insulation to provide a block against living area moisture migrating into the rafter spaces.

Following the above procedures will minimize the potential for condensation-related problems in cathedral or vaulted ceilings.



NO-SLOT VENT

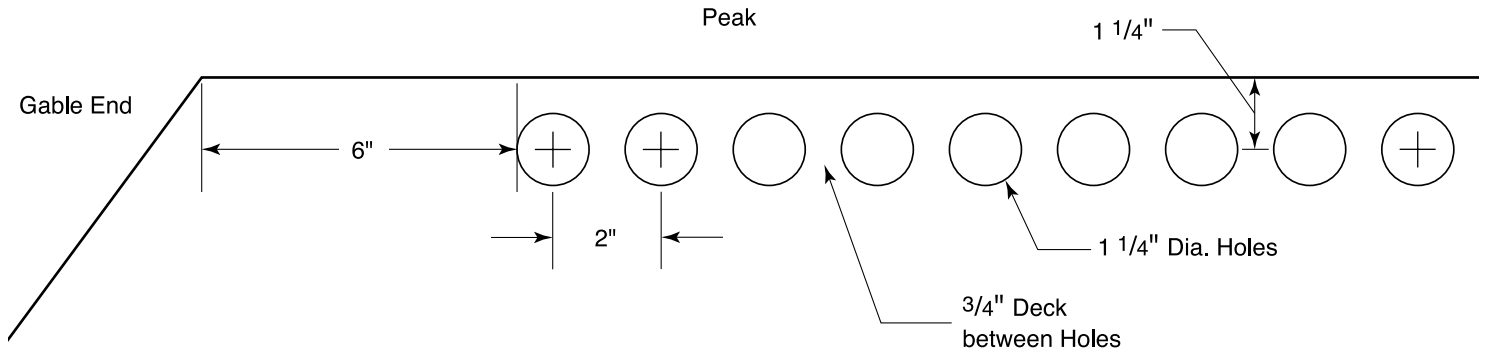

In certain areas of the United States, building codes do not allow for a continuous slot to be cut into the roof structure. This is especially true on the west coast and other earthquake-prone areas. Rapid Ridge can be installed on a roof without a continuous slot.

Drill 1 1/4" holes every 2" on center (this will leave 3/4" of deck between each hole) and 1 1/4" on center from the peak of the roof. From each gable end, leave 6" with no holes cut.

This installation will work with/without the presence of a 2X ridge beam.

Rapid Ridge will vent 4.3 sq. in. per linear foot in this application.



RAPID RIDGE 7 INSTALLATION

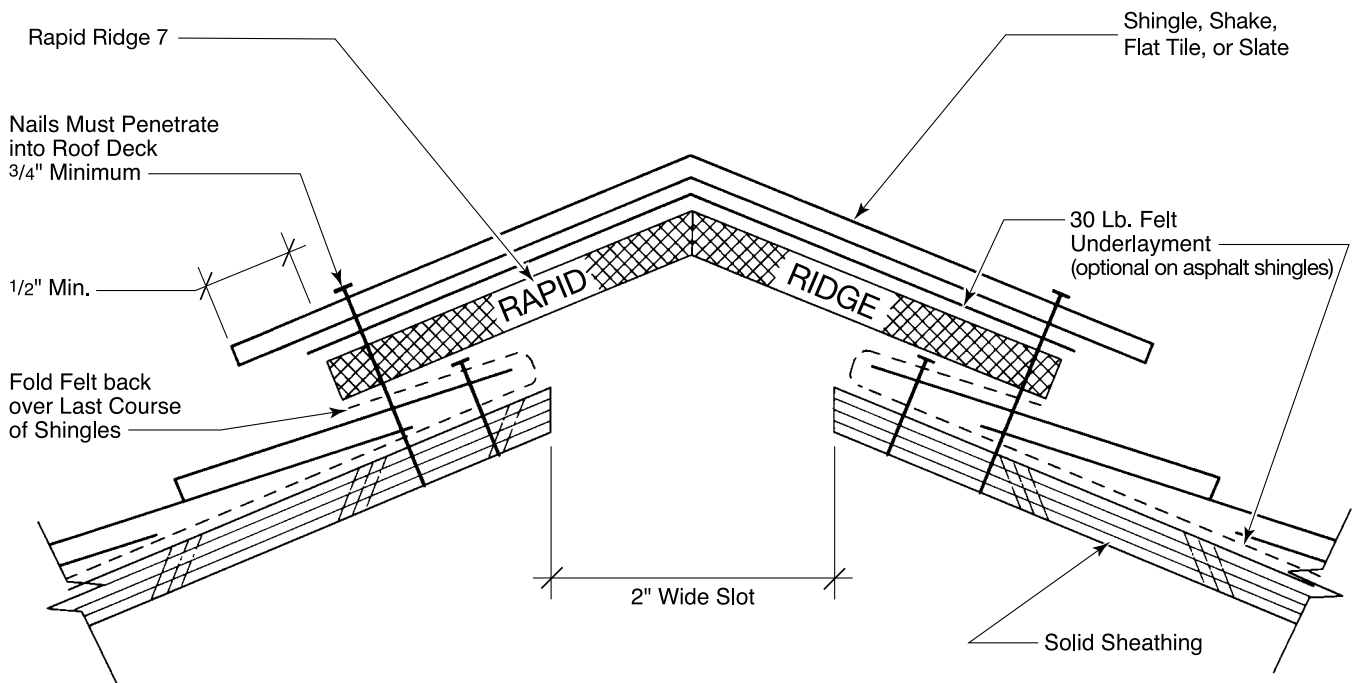

Note: Rapid Ridge 7 can be installed with 8" to 11" cedar, flat tile, slate, or 8" asphalt fiberglass shingles. Rapid Ridge 7 is not recommended for ridge beam applications. Rapid Ridge 7 must be installed on roofs with a minimum of 3/12 pitch and maximum pitch of 12/12. Install with continuous soffit ventilation at each eave equivalent to 7 sq. in. per linear foot.

1. Snap chalk line and cut slot 2" wide (1" on each side). Allow for a closed area of sheathing 12" at both ends of the ridge.
2. Fold 30 lb. felt back over last course of shingles/shakes/tiles exposing 2" slot. (When cutting last course of shingles/shakes/tiles, use caution to avoid cutting through felt.)
3. To create end cap, loosen about 6" of matrix from fabric and cut out with snips. Fold bottom fabric in toward center of product so that it covers the end of vent. Center vent over slot at one end with nail lines "up" and fasten with two nails. Roll out along entire ridge, pull out slack, and fasten with two nails at opposite end (creating end cap at other end). Start and end vent installation 1" from gable ends.
4. Cut exposed excess felt away on shingles/shakes/tiles. In areas of severe weather or rough hand split shakes, lay a bead of caulk between felt and Rapid Ridge 1/4" in from edge for entire length of Rapid Ridge.
5. Install 30 lb felt 7" wide on top of entire length of Rapid Ridge (optional on asphalt shingles).
6. Center ridge cap shingles/shakes/tiles over vent and install with appropriate nails. Use nail length that penetrates into sheathing 3/4" or completely through the sheathing. Nail approximately 1 3/4" in from ridge cap edge on nailing rib indicated by nailing line. Hang shingles 1" over vent at gable ends.
7. To splice, remove about 3" of nylon matrix from fabric and lay end of new roll inside remaining fabric to create fabric overlap.

“CREATING TOMORROW’S INNOVATIVE BUILDING PRODUCTS TODAY”

Benjamin Obdyke Incorporated has been a leading designer and provider of residential building products for over 135 years.

The constant stream of innovations from Benjamin Obdyke helps to drive the residential roofing ventilation industry, from the original ridge vent on a roll to the latest developments in an ever expanding product line.



BENJAMIN OBDYKE INCORPORATED • 199 Precision Drive • Horsham, PA 19044 • www.benjaminobdyke.com
Sales: 800-523-5261 • Customer Service: 800-346-7655 • Fax: 215-672-3731 • Email: info@benjaminobdyke.com